



Eurospan[®] Ceiling System

I. Notes

Thank you for choosing Eurospan[®] as your ceiling solution. The following instructions will guide you through the installation of your new acoustic ceiling. Please read through all of the instructions before beginning.

II. Materials Required

- Eurospan[®] Ceiling fabric
- Fabric retaining track
- Acoustical core
- 1 ¼" Coarse-thread deck screws or
- ¾" Crown ¾" - 1" long 18 gauge wire staples
- Almond colored caulk (optional)
- 1 ⅝" Coarse-thread drywall screws (yellow zinc preferred)
- 1 ⅝" Thick thread drywall laminating screws (as needed)

III. Tools Required

- Safety glasses
- Power miter saw
- Measuring tape
- Step ladder to reach ceiling
- Power screwdriver or pneumatic stapler
- Scissors
- Cotton gloves (provided)
- Drywall/utility knife with heavy duty extension and straight edge (as needed)
- Dust mask for cutting acoustic core
- Eurospan[®] fabric tuck tool

Profiles of Fabric Retaining Track



Perimeter



Mid-Seam

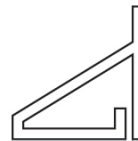

Edge Tuck

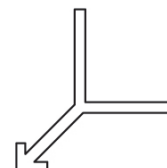

Outside Corner

Disclaimer: The following are guidelines given in good faith to help avoid common errors. They are not intended to be a step-by-step list of instructions or a checklist, and it is assumed the installer has general construction knowledge. Conwed bears no responsibility for any installation actions taken or not taken, and is not responsible for installer selection.



Eurospan[®] Ceiling System

IV. Basic Instructions for a Flat Ceiling

Installing the Fabric Retaining Track to an Existing Drywall Ceiling

1. Choose one corner of the room to start installing the perimeter track. Make a 45° miter cut on the first track piece and place firmly against the wall and ceiling making sure the fabric retaining channel is next to the wall. Using 1 ¼" screws attach the track to the ceiling every 2 to 3 inches or staple it every ¾ to 1 inches. NOTE: It is extremely important not to exceed the required spacing so that the track does not bend under tension from the fabric. This will result in an uneven reveal line next to the wall on the finished ceiling.

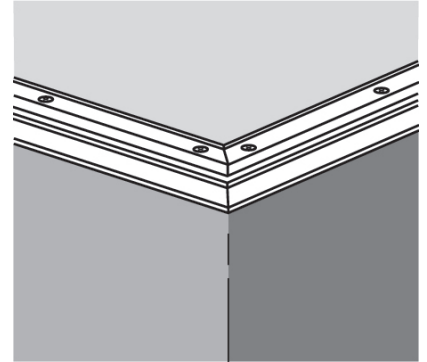

2. Butt and align the next piece of track to the first to create a smooth joint transition, again making sure the fabric retaining channel is next to the wall, and attach to the ceiling. The track sections need to be completely and tightly aligned with each other to provide a seamless finish. Continue this process around the perimeter of the ceiling making miter cuts at each corner.

3. If mid-seam tracks are required, make two 45° miter cuts to create a point on the end of the track that will go next to the wall. Install the mid-seam track with screws or staples. Attach the perimeter track next to the mid-seam track by making 45° miter cuts and butting it against the mid-seam track. Make sure to plan your lay-out ahead, figuring for the widths of the mid-seam track to make sure all the final seams end up in the correct locations.

4. Furring strip can be used to prep a ceiling with an existing open joist ceiling in lieu of an existing gypsum board ceiling. Coordinate all penetration drop distance off the track base down to fabric finish height of 1 ½".

Set Level of Penetrations

5. Penetrations such as lights, smoke detectors, and vents need to be brought down so that their finished trim level is flush with the finished height of the Eurospan[®] fabric. If Eurospan[®] is being installed to an existing ceiling, penetrations need to be dropped down to 1 ½" below existing ceiling.

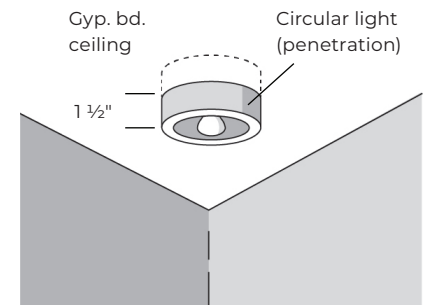

Installing the Acoustic Core

6. Back cut the acoustical panel to fit tight in the track.

7. Starting in one corner of the room, butt the acoustic panel next to the track on both walls. Fasten the panel in place with 1 ⅝" screws on 16" centers.

8. Butt the next panel against the installed panel, making sure to make the joint as tight as possible. Continue this process until the entire ceiling is covered with acoustic panels. Use the matt knife or drywall knife, straight edge, and dust mask to cut any panels to size. Be sure to keep the joints as tight as possible.

9. Once all of the panels are installed, fill the seams with a light coating of the almond caulk. This will prevent the seams from being visible through the installed fabric.



Eurospan® Ceiling System

IV. Basic Instructions for a Flat Ceiling (continued)

Fabric Penetrations

(Insert fabric penetrations AFTER fabric is installed)

10. For circular penetrations less than 8" in diameter, such as recessed lights, speakers, sprinklers or smoke alarms blocking is not needed in most situations. Eurospan® fabric is self supporting and will retain its shape at these penetrations. Note, the openings for these penetrations are cut out after the Eurospan® fabric is fully stretch in place. To cut out the opening, start in the center of where the opening is to be. Start in the center and cut out toward a slightly smaller opening than the penetration is to be. Then push/stretch the fabric up around the trim flange of the penetration; light, sprinkler, smoke detector, etc. This creates the final finish look. Adjust the height of the trim ring or cover trim to final height. This creates the final finish look at most penetrations.

11. For larger circular penetrations or rectangular penetrations there are a few options for finishing. The fabric can be stapled to a wood frame built around the penetration opening at the finished height of the Eurospan® fabric, and finished with the penetration standard trim. Or the Eurospan® perimeter/ top load track can be installed around the penetration opening to hold the fabric in place at the finished height. See the special situations section for instructions on bending the track.

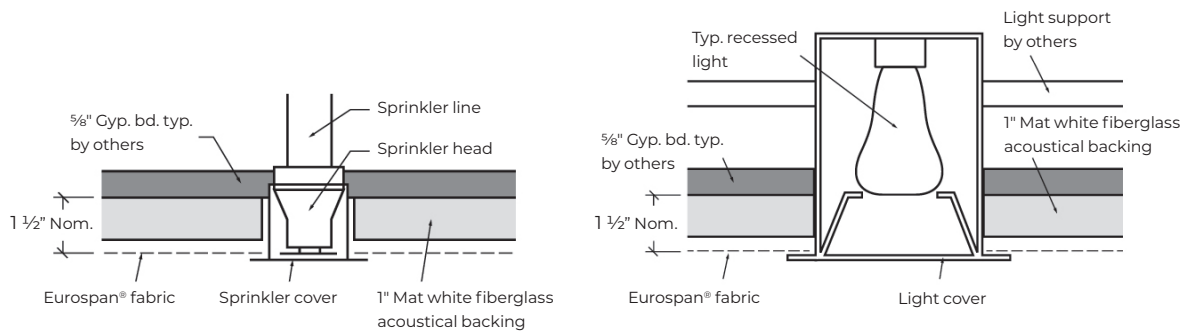

Note: These are general details of a recessed light and sprinkler. Coordination is needed to properly lower and secure the actual project lights, and other penetration to the proper finished height of the Eurospan fabric.

Installing Eurospan® Fabric

12. Before unpacking fabric, clean the workspace thoroughly to protect the fabric from getting soiled.

13. Use the provided white gloves when handling the fabric during installation.

14. Locate the tag on the face of the Eurospan® Fabric that indicates the length and width of the piece of fabric. The tag also indicates the finish face side of the fabric that should be exposed once installed.

15. For the initial part of hanging the fabric. Start in one corner on a short wall, drape 3 to 4 inches of fabric over the tuck tool and insert into the perimeter channel of the retaining track. Remove the tuck tool from the track and the fabric should be held in place.



Eurospan® Ceiling System

IV. Basic Instructions for a Flat Ceiling (continued)

Installing Eurospan® Fabric (continued)

16. Moving down the length of the room, alternate from side to side tucking a tools length of the fabric in the track every 6 ft. Finish by tucking the final side of the fabric into the remaining track. The fabric should now be loosely hanging from the ceiling.

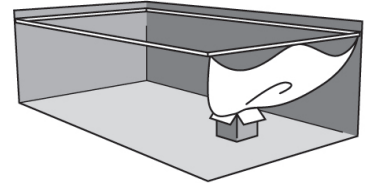

17. Return to the initial wall and tuck the fabric in every 2 to 3 feet. Repeat this process for the remaining three walls. At this point, check to be sure the fabric is square with the room and that it will reach all corners of the room.

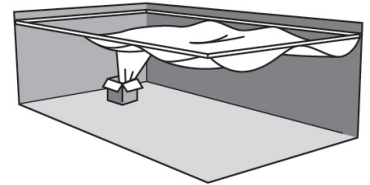

18. In order to start tensioning the fabric, start on a long wall and remove a small portion of the fabric from the track. Pull the fabric tight towards the wall and re-insert. Continue this process down the length of the wall. Move to the opposite wall and repeat this process, adding more tension as you go.

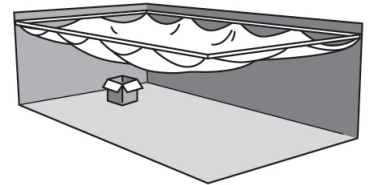

19. Repeat Step 18 for the final two walls.

20. Repeat steps 18 and 19 until the desired tension is achieved. There should be less than 1" deflection in the center of room.

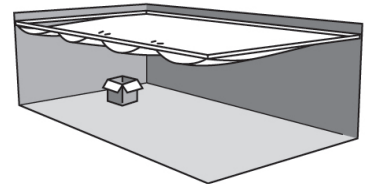

21. Trim the excess fabric hanging below the track leaving only 1 to 2 inches of material. Using the tuck tool, push this excess fabric into the self-storing track.

22. Be sure the fabric direction remains the same between mid-seams and adjacent rooms.

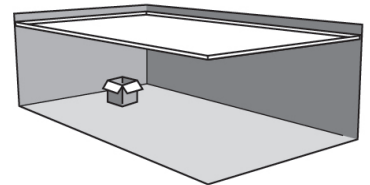

V. Special Situations

Inside and Outside Corners

Inside and outside corners can be created using Eurospan® to accommodate vertical ceiling sections, beams, and duct work. Mid-seam track can be used for making an inside corner (Fig. 1) and outside corner track is also available (Fig. 2). The only requirement is that there must be a structure that will support the track. For example, to enclose a duct, a wood frame can be constructed around the duct to which the track can be attached.

Sloped Ceiling (Fig. 3)

At the base of the sloped ceiling, wood blocking is required to square the perimeter tensioning track to the wall. At the top of the ceiling, wood blocking or edge tuck track can be used to square the track.



Eurospan® Ceiling System

V. Special Situations (continued)

Immovable Post

In order to install Eurospan® around a post, a seam must be created. The seam is created by installing mid-seam track from the post to the nearest wall. The installation is carried out as described in the basic instructions to tension the fabric on three of the walls. Once the fabric is tight against the post on one side, the fabric is cut and wrapped around the post. Tuck the fabric into the fourth wall and the mid-seam track to finish the ceiling.

Creating Curves

Eurospan® can be installed on domed ceilings or in curved shapes by bending the track. In order to curve the track, multiple kerfs can be cut into the perimeter or mid-seam track. To cut kerfs only use a plywood blade. Set the saw depth so that each kerf is the same depth. Use wood blocking on the saw back to help position the saw blade correctly. Kerf the track every 1 1/4" and keep the spacing even for an even flex. Use masking tape on the installed track to stop visual bleed through of the kerfs.

Creating a Finished/Exposed Edge (Fig. 4)

For installations where the fabric ceiling is not extended to a wall, a finished edge can be created to hide the fabric retaining track. There are two ways that a finished edge can be created.

A. Edge Tuck Track: Instead of using perimeter track for the exposed edge, the edge tuck track can be substituted. This track allows the fabric to be tucked parallel to the ceiling concealing the track.

B. Fabric Wrapped Edge: A narrow piece of fabric (3–4") can be installed between the track and the ceiling with the excess fabric on the tuck side. Tuck the excess fabric into the track to create a fabric wrapped edge.

Fig. 1

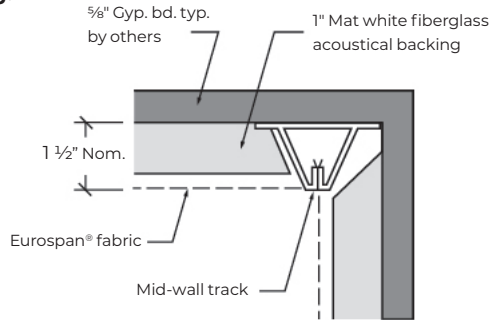

Fig. 2

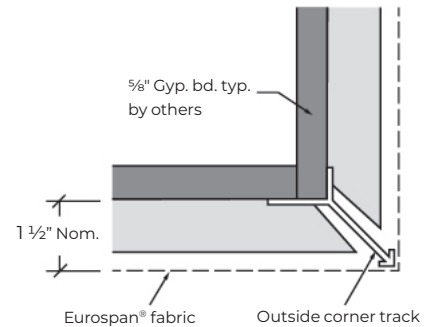

Fig. 3

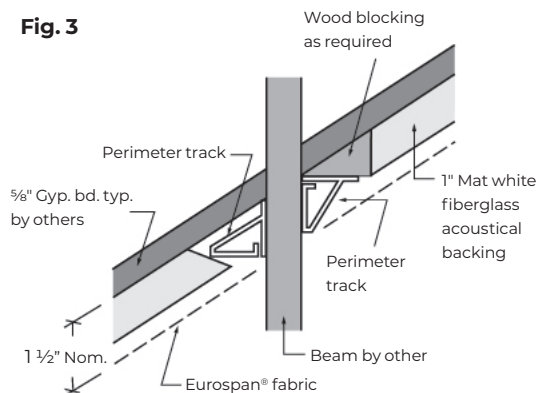

Fig. 4

